

**RG-400 Vegetable Preparation Machine**

No. on drawing	Item No.	Spare Part	Reservdel	Incl.Pcs
10	3110	HANDLE KNIFE CHAMBER	HANDTAG,KNIVHUS	1
20	14376	SCREW MCS M8X30 A2 70	SKRUV MCS M8x30 A2 70	2
30	3086	EJECTOR PLATE	UTMATARSKIVA	1
40	10344	PLUG GL 320 BLACK	ÄNDAVSLUTNING GL 20 svart	2
50	10311	SEAL RING V-35S	TÄTNINGSRING V-35S	1
60	3113	KNIFE CHAMBER	KNIVHUS	1
70	3180	KNIFE SHAFT COMPL.	KNIVAXEL KOMPL.	1
73	40548	CARRIER PIN	MEDBRINGARPINNE	1
75	14844	LOCKING SCREW PSS M8X12 A2 70	SKRUV LÅS PSS M8x12 A2 70	1
80	3152	CARRIER PIN FOR EJECTOR PLATE	MEDBRINGARPINNE, UTMATARSKIVA	1
90	10325	O-RING SEAL 17.1X1.6	O-RING 17.1x1.6	1
100	15586	SAFETY SWITCH KB5FKR-ULS	MICKROBRYT. KB5FKR-ULS	3
110	14308	SCREW MCS M3X20 A2 70	SKRUV MCS M3x20 A2 70	6
120 1)	33317	SHAFT F SAFTEY SWITCH M99	AXEL F.BRYTARE M99	1
	3125	SHAFT F SAFTEY SWITCH	AXEL F.BRYTARE	1
130	3126	THRUST PLATE	BRYTSKIVA	1
140	10324	SPRING, SAFETY SWITCH 22510	FJÄDER F. BRYTARE 22510	1
150	3124	BRACKET F SAFTEY SWITCH	FÄSTVINKEL FÖR BRYTARE	1
160	14512	SKREW M65 M5X 10H A2	SKRUV M65 M5X 10H A2 70	3
170	15439	PUSH BUTTONS O COMPL.	TRYCKKNAPP O KOMPL.	1
180	15440	PUSH BUTTONS 1 COMPL.	TRYCKKNAPP I KOMPL.	1
190	10323	O-RING SEAL DIA. 2,4 L=325	O-RINGSSNÖRE DIA. 2.5 L=325	1
200	3096	COVER PLATE	TÄCKPLÅT	1
210	14662	SCREW KFSS ST3.5X13 A2 70	SKRUV KFSS ST3.5x13 A2 70	6
220	14564	SCREW M6S M10X30 A2 70	SKRUV M6S M10x30H A2 70	1
230	14090	WASHER FBB 10.2 A2	BRICKA FJÄDER FBB 10.2 A2	1
240	3159	WASHER FOR GEER WHEEL, MOTOR	BRICKA FÖR KUGGHJUL, MOTOR	1
250	3061	PULL ROD M 8	DRAGSTÅNG M8	4
260	3083	GEAR WHEEL 52.6	KUGGHJUL 52.6	1
270	3057	GEAR WHEEL 173.2	KUGGHJUL 173.2	1
280	14544	SCREW M6S M8X22H A2 70	SKRUV M6S M8x22H A2 70	5
290	14088	LOCK WASHER FBB 8.2 A2	BRICKA FJÄDER FBB 8.2 A2	11
300	3060 4	MACHINE CAISING LEFT PART	MASKINHUS VÄNSTER SIDOSTYCKE	1
310	3158	WASHER GEER WHEEL, KNIFE SHAFT	BRICKA FÖR KUGGHJUL K-AXEL	1
320	3130	BRACKET F HANDLE LOCKING	FÄSTVINKEL HANDTAGSLÅSNING	1
330	3107	ROLLER LOCKING HANDLE	RULLE, LÅSHANDTAG	2
340	10326	LOCK RING SGA 8 SS	LÅSRING SgA 8 RFR	2
350	14084	LOCK WASHER FBB 4.1 A2	BRICKA FJÄDER FBB 4.1 A2	1
360	14629	SCREW RTK ST3,5X9,5	SKRUV RTK ST3,5x9,5	2
370	10342	SEAL RING BASL 42X55X7	TÄTNINGSRING BASL 42X55X7	1
380	3060 1	MACHINE CAISING FRONT PART	MASKINHUS FRAMSTYCKE	1
390	3078	LOCK HANDLE	LÅSHANDTAG, MASKINENHET	1
400	3111	TENSION SPRING	DRAGFJÄDER	2
410	3089	BUSHING F LOCK HANDLE	BUSSNING F.LÅSHANDTAG	2
420	14849	SCREW TSS 8X25 A2 70	SKRUV TSS M8x25 A2 70	2
430	3108	STOPPER F LOCK HANDLE	STOPP F. LÅSHANDTAG	1
440	14845	SCREW TSS 8X15 A2 70	SKRUV TSS M8x15 A2 70	1
450	14008	NUT M6M M8 A2 70	MUTTER M6M M8 A2 70	1
460	3154	PROTECTION TUBE	RÖRSKYDD, FOT	2
470	10328	RUBBER FOOT NO. 19M 10X60	FOT GUMMI NR19 M10x60	2
480	10318	SEAL RING BASL 25X40X7	TÄTNINGSRING BASL 25X40X7	1
490	10320	BALL BEARING 6205-2RS	KULLAGER 6205-2RS	1
500	3055	SPACER RING 41/52	DISTANS 41/52	1
510	10319	BALL BEARING 6304 2RS	KULLAGER 6304 2RS	1
520	3054	BALL BEARING COVER	KULLAGERLOCK	1
530	3056	SPACER RING 20/28	DISTANS 20/28	1
540	14443	SCREW LSKS M5X12 A2 70	SKRUV LSKS M5X12 A2 70	4
550	3112	SAFETY GUARD	UTLOPPSSKYDD	1
560	10321	KEY PKR 6X6X16	KIL PKR 6x6x16	1

**RG-400 Vegetable Preparation Machine**

No. on drawing	Item No.	Spare Part	Reservdel	Incl.Pcs
570	14085	LOCK WASHER FBB 5,1 A2	BRICKA FJÄDER FBB 5.1 A2	4
580	14343	SCREW MCS M5X12 A2 70	SKRUV MCS M5x12 A2 70	4
590	3120	MOTOR BEARER	MOTORFÄSTE	1
600	3191	WIRING LOOM MACHINE UNIT	KABELSTAM AWG MASKINENHET	1
610	3060 3	MACHINE CAISING BACK PART	MASKINHUS BAKSTYCKE	1
620	3177	SUPPLY CORD STD	KABEL, EL-BOX, INKOMMANDE-STD	1
625	3193	SUPPLY CORD US	KABEL, EL-BOX, INKOMMANDE-US	1
630	15381	CABLE RET PR 22.5 DIA 15 METAL	DRAGAVLASTARE PR22,5 DIA15 MET	1
640	15443	NUT PR 22.5/PG16 METAL	MUTTER, METALL PR 22.5/PG16	1
650	3060 2	MACHINE CAISING RIGHT PART	MASKINHUS HÖGER SIDOSTYCKE	1
660	14551	SCREW M6S M8X60 A2 70	SKRUV M6S M8x60 A2 70	3
670	15432	MOTOR 208/220 3 60 4-8UL	MOTOR 208/220 3 60 4-8 UL	1
678	15435	MOTOR 400/415 3 50, 440/460	MOTOR 400/415 3 50, 440/460 3	1
680	15229	CABLE RETAINER PR22,5	DRAGAVLASTARE PLAST PR22,5	1
690	15326	NUT 22.5/PG16 PLASTIC	MUTTER PLAST PR22.5/PG16	2
700	15442	POLE CHANGING SWITH INCL KNOB	POLOMK. CM0012R 194L-E12 MVRED	1
710	14602	SCREW FSS ST2,9X13 A2 70	SKRUV FSS ST2,9X13 A2 70	2
720	15589	TRANSFORM. 208-240V/22-26V UL	TRANSFORM.208-240V/22-26V UL	1
721	15611	TRANSFORM.400/380V-24 50VA	TRANSFORM.400/380V-24 50VA	1
722	15689	TRANSFORM.440/415V-24 100VA	TRANSF.440/415V-24 100VA 80C	1
730	15532	OVERL. REL.LR2-K0310 2.6-3.7A	MOTORSKYDD LR2-K0310 2.6-3.7A	1
735	15534	OVERLOAD REL.LR2-K0314 5.5-8.0	MOTORSKYDD LR2-K0314 5.5-8.0A	1
740	15520	CONT.LC1-K0610B7 24V 50/60	KONT.LC1-K0610B7 24V 50/60	2
750	14713	SCREW RX-PT 3,5X13 C1	SKRUV RX-PT 3,5X12 FZB	8
760	15441	CONTACTOR BOX	APPARATLÅDA	1
770	15193	GROUND PLATE M4	JORDSKYLTT, GUL 12,5x12,5	1
780	14731	SCREW RXK-H ST4,8X9,5	SKRUV RXK-H ST4,8X9,5	6
790	3195	WIRING LOOM POLE CHANGING SW.	KABELSTAM AWG POLOMKOPPLARE	1
800	15226	CABLE SEAL 20,4	KABELGENOMFÖRING PR20,4	2
810	3192	WIRING LOOM, AWG EL-BOX	KABELSTAM AWG EL-BOX	1
820	3194	WIRING LOOM, AWG MOTOR	KABELSTAM AWG MOTOR	1
830	14028	NUT MHM M8 A2 70	MUTTER HATT MHM M8 A2 70	2
840	3117	BASE	FOTPLATTA	1
850	14553	SCREW M6S M8X70 A2 70	SKRUV M6S M8x70 A2 70	2
860	10327	WHEEL 85 RNP	HJUL 85 RNP	2
870	10374	WASHER 3MM NYLON	BRICKA 3MM NYLON	4
880	3109	SHAFT F LOCK HANDLE	AXEL F.LÅSHANDTAG	1
890	3143	FAN PLATE	VENTILATIONSPLÅT	1
900	10322	O-RING 236,5X2,4	O-RING 234,62X2,62	1
910	10350	GREASE FOR GEAR BOX, GB0, 1 KG	FETT FÖR VÅXELLÅDA, GB0,	1

<sup>1)</sup> For machines bought before 1999 use Item No. 3125

**Drawing: Vegetable Preparation Machine RG-400**

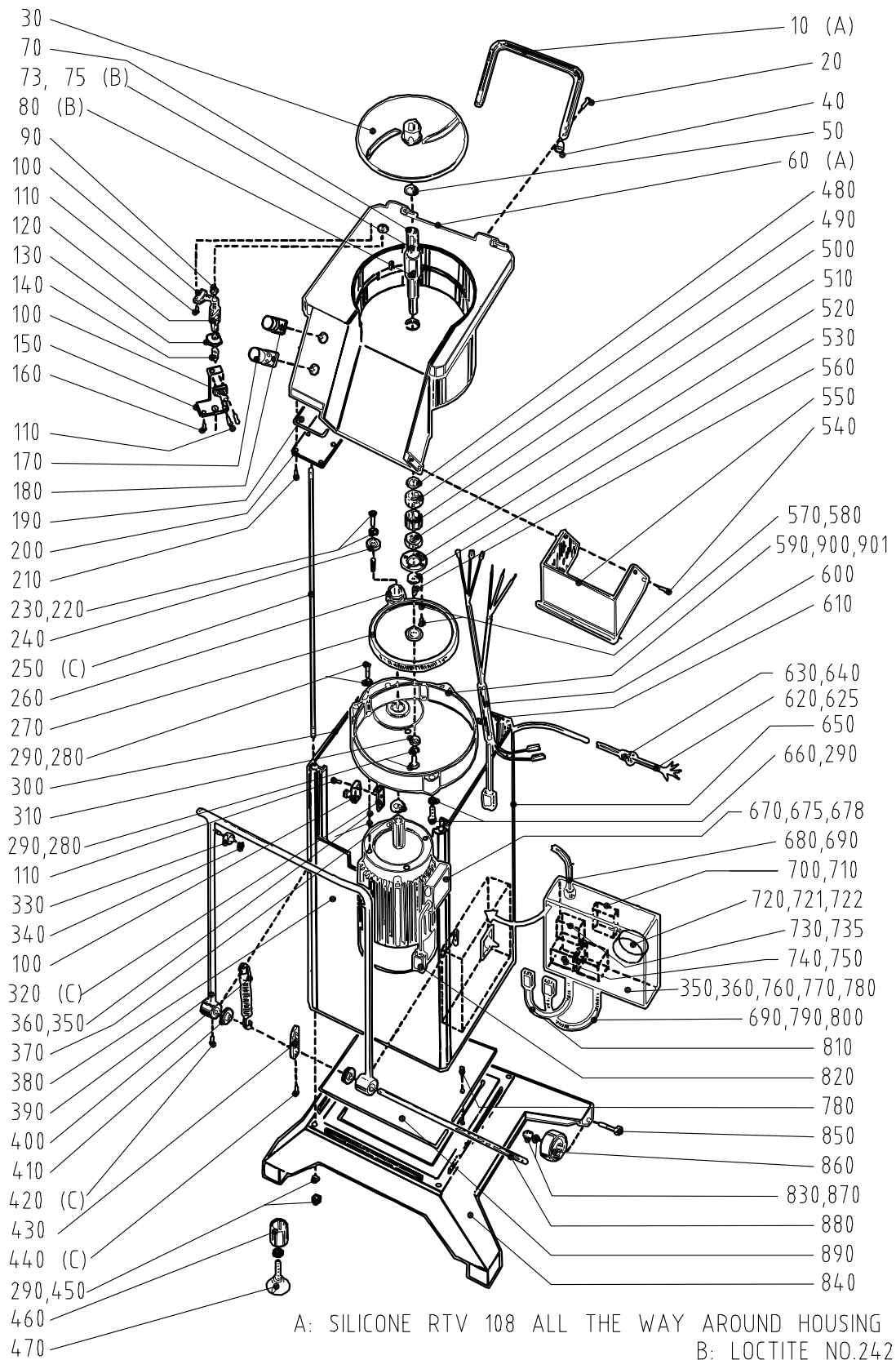

## RG-400 Vegetable Preparation Machine – Feed Hopper

No. on drawing	Item No.	Spare Part	Reservdel	Incl.Pcs
10	3280	KNOB	KNOPP	1
20	14464	SCREW LSKS M6X16	SKRUV LSKS M6X16	2
30	3281	PLASTIC WASHER 18-6-2	BRICKA PLAST 18-6-2	2
50	10345	PLUG GL 28 BLACK	TÄCKPROPP GL 28 svart	1
60	3149	STUD SCREW	PINNSKRUV	1
70	10454	BALL RB-6,35, STAINLESS STEEL	KULA RB-6,35 ROSTFRI	1
80	10453	SPRING 1X5X17	TRYCKFJÄDER 1x5x17	1
90	10343	HANDLE I280/65-M8	HANDTAG I280/65-M8	1
100	3131	BAYONET PIN	TAPP BAJONETT	1
110	3253	BAYONET SLEEVE	BAJONETTHYLSA	1
120	14243	SCREW MKFS M5X10	SKRUV MKFS M5X10 RF	2
130	3266	BUSHING	BUSSNING	1
140 1)	33319	SHAFT M99	AXEL M99	1
	3094	SHAFT	AXEL,TRATT -MÅNGHÅLSINS	1
150	3234	LOCKING CLUTCH FOR FEED CYL.	LÅSHAKE TILL MATARCYLINDER	1
160	3281	PLASTIC WASHER 18-6-2	BRICKA PLAST 18-6-2	1
170	10436	PLASTIC WASHER 05-6-15-3	BRICKA PLAST 05-6-15-3	1
180	33307	FEED CYLINDER FOR HOPPER	MATARCYLINDER TRATTMATARE	1
190	3076	BUSHING 25/34	BUSSNING MATARINSATS 25/34	1
200	3068	BUSHING COVER	BUSSNINGSHÅLLARE	1
210	14682	SCREW KFSS ST4,8X13	SKRUV KFSS ST4,8X13	3
220	14026	DOMED HEAD NUT MHM M6	MUTTER HATT MHM M6	5
230	3247	CRANK FOR HOPPER	OMRÖRARARM	1
240	3161	HOPPER INSERT	TRATTINSATS	1
250	3246	STIRRER FOR HOPPER	OMRÖRARE	1
260	3232	GUIDE	MATARBÅS (KORT)	2
270	14864	STUD SCREW PSH M6X25	SKRUV PINN PSH M6X25	4
280	3249	AGITATOR DEVICE COMPL.	SKRUVKAPSEL KOMPL.	1
290	3162	WRENCH	NYCKEL TILL KÅLSKRUV	1
300	10521	SOCKET WRENCH NV10	HYLSNYCKEL NV10	1
310	33328	HOPPER INSERT, COMPLETE	TRATTINSATS KOMPLETT	1

1) For machines bought before 1999 use Item no. 3094.

### Drawing: Vegetable Preparation Machine RG-400 Feed Hopper

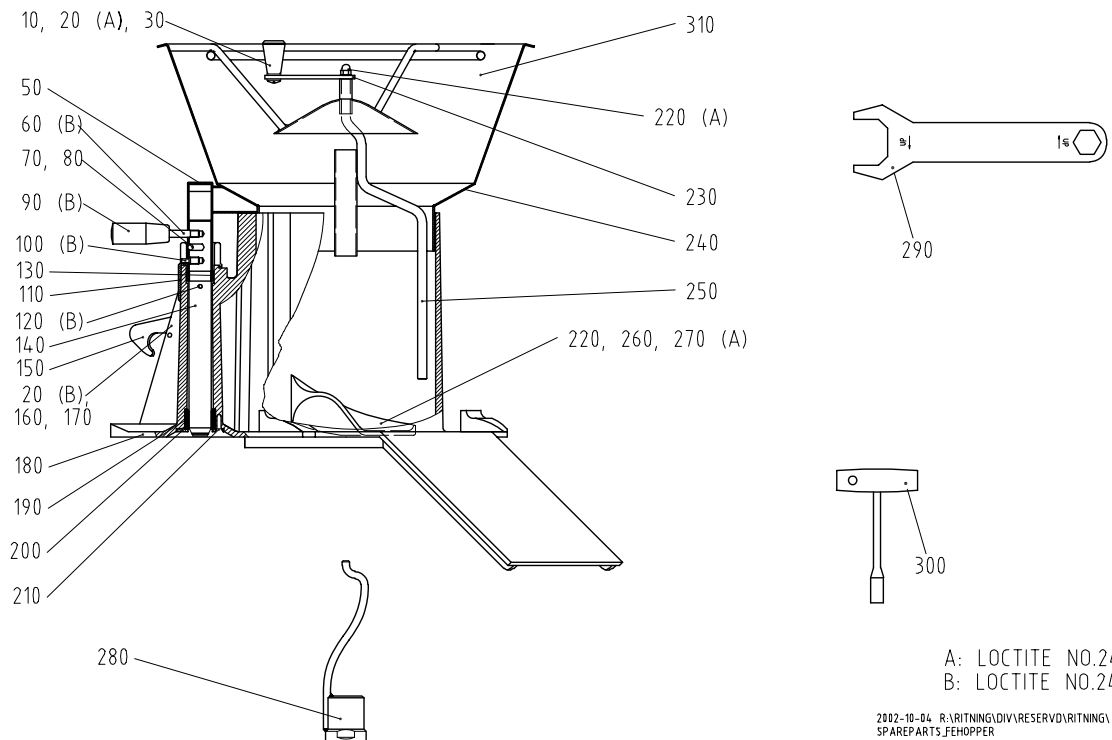

## RG-400 Vegetable Preparation Machine – Feed Cylinder for Push Feed Attachment and 4-tube Attachment

No. on drawing	Item No.	Spare Part	Reservdel	Incl.Pcs
10	33305	SLIDE KNOB DIA. 10X4	GLIDKUTS DIA. 10X3,75	1
20	10331	RIVET, PLASTIC 93-4 BLACK	PLASTNIT SVART 93-4 SVART	2
30	14714	SCREW CSS ST3,5X9,5	SKRUV CSS ST3,5X9,5	1
40	3085	STOPPER, 4-TUBE/PUSH FEED ATT	STOPPKLACK MATARINSATS	1
50	3253	BAYONET SLEEVE	BAJONETTHYLSA	1
60	10334	SPRING ST-TFR 0,5X4X35	FJÄDER ST-TFR 0,5X4X35	1
70	14243	SCREW MKFS M5X10	SKRUV MKFS M5X10 RF	2
80	33306	FEED CYLINDER	MATARCYLINDER, MANUELL M.	1
90	3234	LOCKING CLUTCH FOR FEED CYL.	LÅSHAKE TILL MATARCYLINDER	1
100	3281	PLASTIC WASHER 18-6-2	BRICKA PLAST 18-6-2	1
110	10436	PLASTIC WASHER 05-6-15-3	BRICKA PLAST 05-6-15-3	1
120	14464	SCREW LSKS M6X16	SKRUV LSKS M6X16	1
130	3076	BUSHING 25/34	BUSSNING MATARINSATS 25/34	1
140	3068	BUSHING COVER	BUSSNINGSHÅLLARE	1
150	14682	SCREW KFSS ST4,8X13	SKRUV KFSS ST4,8X13	3
160	3134	KNIFE	KNIV MATARINSATS	3
170	3233	DOMED HEAD NUT M5	MUTTER M5 TILL KNIV	9
180	14326	SCREW MCS M4X16	SKRUV MCS M4X16	1
190	14004	NUT M6M M4 A2 70	MUTTER M6M M4 A2 70	1

**Drawing: Feed Cylinder for Push Feed Attachment and 4-tube Attachment**

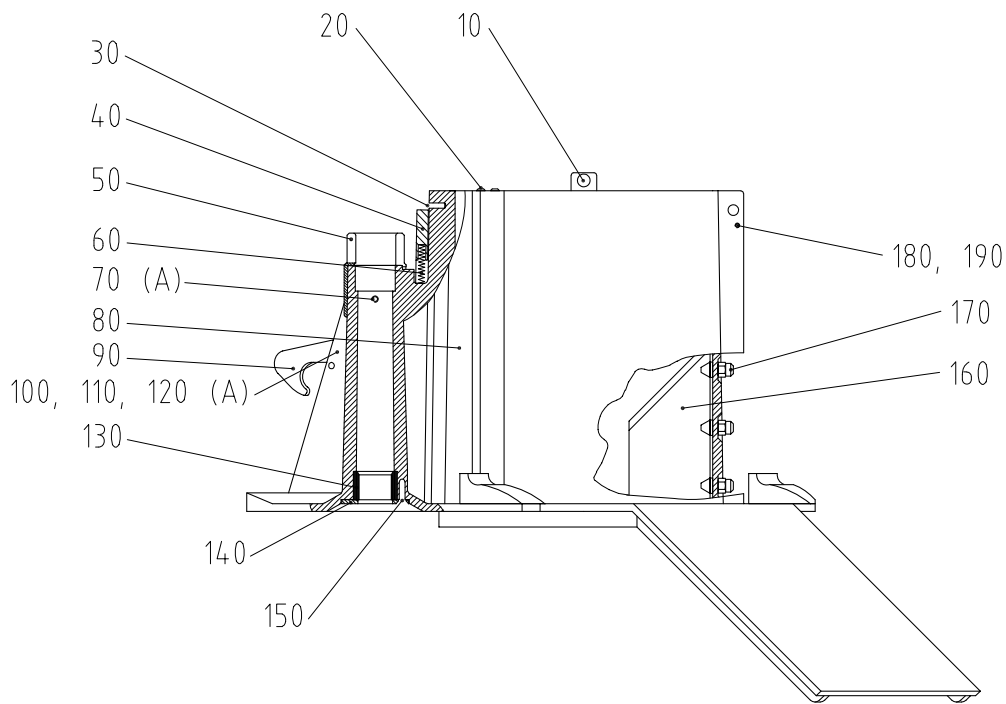

A: LOCTITE NO.243

2002-10-04 R:\RITNING\DIV\RESERVD\RITNING\  
SPAREPARTS\_PUFE4.TUB

## RG-400 Vegetable Preparation Machine – 4-tube Attachment

No. on drawing	Item No.	Spare Part	Reservdel	Incl.Pcs
10	3254	STAND	ARM	1
20	3149	STUD SCREW	PINNSKRUV	1
30	10343	HANDLE I280/65-M8	HANDTAG I280/65-M8	1
40	10454	BALL RB-6,35, STAINLESS STEEL	KULA RB-6,35 ROSTFRI	1
50	10453	SPRING 1X5X17	TRYCKFJÄDER 1x5x17	1
60	3131	BAYONET PIN	TAPP BAJONETT	1
70*	3266	BUSHING	BUSSNING	1
80* 1	33319	SHAFT M99	AXEL M99	1
	3094	SHAFT	AXEL,TRATT -MÅNGHÅLSINS	1
90	3123	4-TUBE INSERT INCL. STAND	4-HÅLSPROFIL INKL. PLUGGAR	1
100	3251	WASHER	BRICKA	2
110	14484	SCREW LSXS M8X16	SKRUV LSXS M8X16	2
120	10329	PLUG IR20/40/1,5 S	ÄNDAVSLUTNING IR20/40/1,5 S	1
130	10455	PLUG IKPT 1715S	TÄCKPROPP IKPT 1715S	2
140	3256	SPACER 25	DISTANS 25	1
150	3255	SPACER 16	DISTANS 16	1
160	14395	SCREW MC6S M8X40	SKRUV MC6S M8X40	2
170	3279	SIGN WARNING	SKYLT VARNING	1
180	14881	RIVET KDS 2X4,5	DRIVNIT KDS 2X4,5	2
190	10345	PLUG GL 28 BLACK	TÄCKPROPP GL 28 svart	1
200	3139	PESTLE DIA. 55	STÖT DIA. 55	1
210	3138	PESTLE DIA. 31	STÖT DIA. 31	1
220	3204	LOCKING BOLT TR12V	LÅSBULT TR12V KORT KOMPL.	1
*70-80	33354	SHAFT W. BUSHING M99	AXEL M. BUSSN, TRATT, 4-H M99	1

1) For machines bought before 1999 use Item No. 3094

### Drawing: Vegetable Preparation Machine RG-400 4-tube Attachment

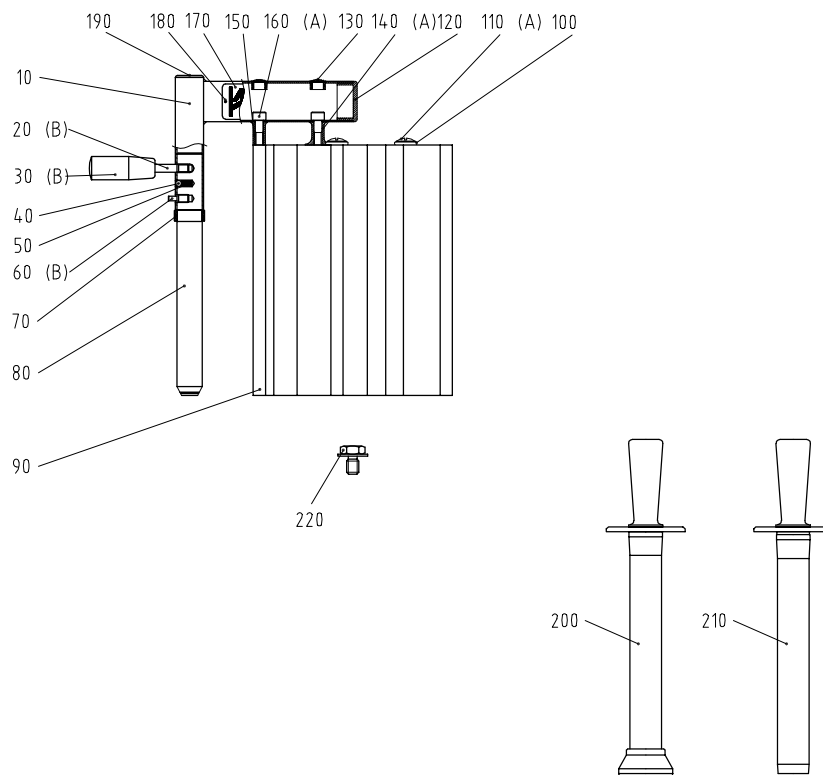

A: LOCTITE NO.242  
B: LOCTITE NO.243

## RG-400 Vegetable Preparation Machine – Push Feeder Manual

No. on drawing	Item No.	Spare Part	Reservdel	Incl.Pcs
10	3298	PIVOT L=38	LAGERTAPP L=38	1
20	10335	LOCK RING SGA 10, STAINL.STEEL	LÅSRING SGA 10 ROSTFRI	6
30	3067	LEVER	HÄVARM	1
50	3066	LINK	LÄNK	1
60	3297	PIVOT L=51	LAGERTAPP L=51	1
70	3119	STAND	STATIV	1
80	3212	PIN FOR STAND L=28	TAPP STATIVARM L=28	1
90	14149	SCREW MFS M5X16	SKRUV MFS M5X16	1
100	3077	BUSHING 23/31	BUSSNING MATARINSATS 23/31	1
110 1)	33318	SHAFT STAND M99	AXEL STATIV M99	1
	3064	SHAFT,STAND	AXEL STATIV	
120	10452	PLUG SFL 14	TÄCKPROPP SFL 14	1
130	3116 1	FEED CYLINDER INCL. SHAFT	MATARPLATTA INKL. AXEL	1
140	3257	GUIDE KNOB	GLIDKUTS MATARKOLV	3
150	3095	BUSHING FOR STAND	BUSSNING STATIV	2
160	3299	PIVOT L=34	LAGERTAPP L=34	1
170	3129	DECORDING DEVICE 3PH COMPL.	KÅLSKRUV 3-FAS KOMPL.	1
180	3162	WRENCH	NYCKEL TILL KÅLSKRUV	1

1) For machines bought before 1999 use Item No. 3064

### Drawing: Vegetable Preparation Machine RG-400 Push Feeder Manual

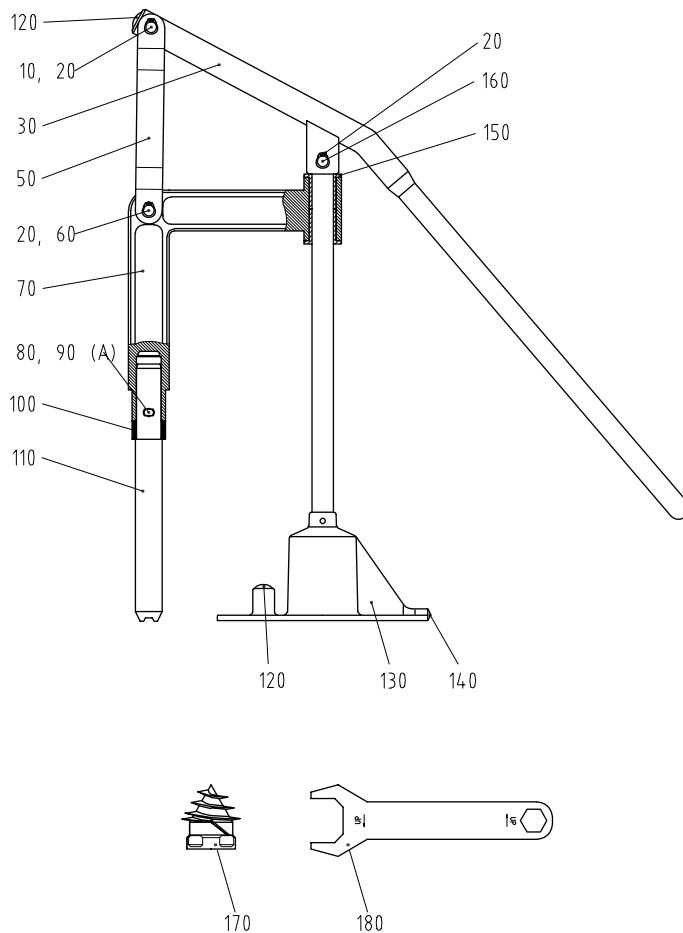

A: LOCTITE NO.243

**RG-400 Vegetable Preparation Machine – Push Feeder Pneumatic**

No. on drawing	Item No.	Spare Part	Reservdel	Incl.Pcs
10	3098	STAND	STATIVARM	1
20	3212	PIN FOR STAND L=28	TAPP STATIVARM L=28	1
30	14149	SCREW MFS M5X16	SKRUV MFS M5X16	1
40	3077	BUSHING 23/31	BUSSNING MATARINSATS 23/31	1
50	33318	SHAFT STAND M99	AXEL STATIV M99	1
60	3106	BEARING HOLDER	LAGERHUS	1
70	10348	BUSHING PM12/14X15DX	BUSSNING PM12/14X15DX	2
80	3101	NUT M18	MUTTER M18	1
90	3080	OPERATION ROD	MANÖVERSTÅNG	1
100	33378	PISTON, HD	MATARKOLV, HD	1
110	3257	GUIDE KNOB	GLIDKUTS MATARKOLV	3
120	14224	SCREW MKFS M4X12	SKRUV MKFS M4X12	4
130	3295	NUT M16X1,5 LOW	MUTTER M16X1,5 LÅG	1
140	14542	SCREW M6S M8X16H A2 70	SKRUV M6S M8x16H A2 70	4
150	10232	HOSE CLAMP 8-14	SLANGKLAMMER 8-14	1
160	10329	PLUG IR20/40/1,5 S	ÄNDAVSLUTNING IR20/40/1,5 S	1
170	10367	SIGN 1-3-2	SKYLTY ZBY0101 (1 3 2)	1
180	14374	SCREW MCS M8X20 A2 70	SKRUV MCS M8x20 A2 70	1
190	3099	CAP	KÅPA	1
200	14012	NUT M6M M12	MUTTER M6M M12	1
210	3105	THRUST WASHER	TRYCKBRICKA	1
220	14230	SCREW MKFS M4X30	SKRUV MKFS M4X30	2
230	14004	NUT M6M M4 A2 70	MUTTER M6M M4 A2 70	3
240	14084	LOCK WASHER FBB 4.1 A2	BRICKA FJÄDER FBB 4.1 A2	2
250	40656	SIGN WARNING	SKYLTY VARNING HAND REKTANGEL	1
270	3129	DECORING DEVICE 3PH COMPL.	KÅLSKRUV 3-FAS KOMPL.	1
300	10109	VALVE 234-000	VENTIL 234 000	2
310	10354	VALVE 245 000	VENTIL 245-000	2
320	10355	REGULATOR C-1104-D00-1/4	FILTERREGULATOR C-104-D00-1/4	1
330	10356	VALVE REDUSER MCO-702-M5	STRYPVENTIL MCO-702-M5	2
340	10282	PRESS.GAUGE M043 P12 1/8 40 MM	MANOMETER M043 P12 1/8 40 MM	1
350	10112	ADAPTOR 5180 1/4	SNABBKOPPLINGSNIPPEL 5180 1/4	1
360	10357	QUICK CONNECTOR 5084-10/8	SNABBKOPPLING 5084-10/8	1
370	10120	TEE 2070-1/4	T-NIPPEL 2070-1/4	1
380	10358	COUPLING 6512-4-M5	RAK KOPPLING 6512-4-M5	2
390	10095	COUPLING 6510-8-1/4	RAK KOPPLING 6510-8-1/4	2
400	10359	COUPLING 6510-8-1/8	RAK KOPPLING 6510-8-1/8	2
410	10117	ELBOW COUPLING 6520-4-1/8	VINKELKOPPLING 6520-4-1/8	4
420	10360	ELBOW COUPLING 6520-8-1/8	VINKELKOPPLING 6520-8-1/8	1
430	10361	ELBOW COUPLING 6520-4-1/4	VINKELKOPPLING 6520-4-1/4	1
440	10119	CROSS COUPLING 6600-4	KORSKOPPLING 6600-4	1
450	10362	COUPLING Y 6560-4	Y-SKARV 6560-4	2
460	10363	SILENCER 2991-1/8	LJUDDÄMPARE 2991-1/8	1
470	10364	SILENCER 2905-M5	LJUDDÄMPARE 2905-M5	2
480	10492	PUSH BUTTON 200-895 START/STOP	TRYCKKNAPP 200-895 START/STOP	2
490	10366	HOSE NIPPLE 2601-9-1/4	SLANGNIPPEL 2601-9-1/4	1
500	10234	NYLON PIPE PA12 4-2,7	SLANG PA12 4-2,7	1
510	10235	NYLON PIPE PUR-8/5,7 BLUE	SLANG PUR-8/5,7 BLÅ	1
520	10368	HOSE PV10/8 BLUE	SLANG PV10/8 BLÅ	1
530	10289	VALVE 5110 1/4 INCOMING AIR	VENTIL AVSTÄNGNING 5110 1/4	1
540	10387	BRACKET FOR C-114-ST	FÄSTVINKEL FÖR REG C-114-ST	1
550	10493	TWIST KNOB 200-870 SPEED CONTR	VRED 200-870 HASTIGHETSKONTROL	1
560	10104	HEX ADAPTER 1/4 MALE THREAD	NIPPEL 1/4 UTV GÄNGA	1
570	10490	CYL. 41S-2R-050-0250-V, COMPL.	CYLINDER 41S-2R-050-0250-V, KO	1
570	33311	GASKET KIT FOR CYL.41S	PACKNINGSSATS FÖR CYL.41S-50	1
580	10352	VALVE 358-033-1/8	VENTIL 358-033-1/8	1
590	10108	VALVE 234-945	VENTIL GRÄNSLÄGE 234-945	2
600	10353	VALVE OR 81540 001	VENTIL OR 81540 001	1
610	10240	VALVE 7880-08-13	BLOCKERINGSVENTIL 7880-08-13,	1

**Drawing: Vegetable Preparation Machine RG-400 Push Feeder Pneumatic**

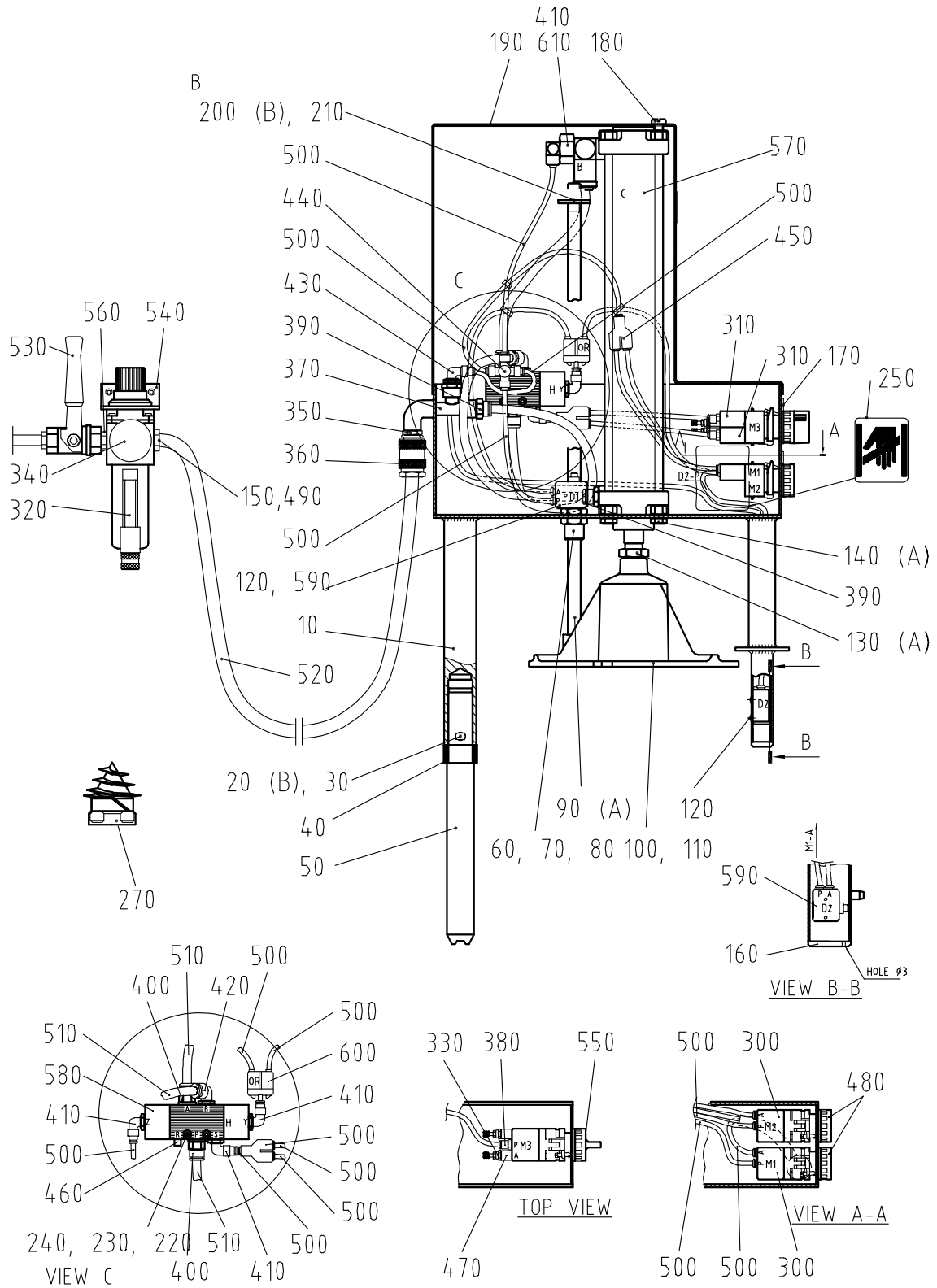

THREAD LOCKING COMPOUND: LOCTITE 577

A: LOCTITE NO.242

B: LOCTITE NO.243

## Cutting Tools 215 mm, RG-300/350/400 and for RG-6/61/1

Cutting Tool name	No. on drawing	Item No.	Spare Part	Reservdel
<b>Standard Slicer</b>	10	3360	KNIFE, STANDARD SLICER	KNIV, STANDARDSKIVARE
<b>Fine Cut Slicer</b>	20	3466	KNIFE, FINE CUT SLICER	KNIV, FINSNITTSKIVARE
<b>Crimping Slicer</b>	30	3411	KNIFE, CRIMPING SLICER	KNIV, RÄFFELSKIVARE
<b>Julienne Cutter</b>	10	3360*	KNIFE, STANDARD SLICER	KNIV, STANDARDSKIVARE
		3360*	KNIFE, STANDARD SLICER	KNIV, STANDARDSKIVARE
		3360*	KNIFE, STANDARD SLICER	KNIV, STANDARDSKIVARE
	40	62040	HORIZONTAL KNIFE, 4,5X4,5 MM	HORISONTALKNIV, 4,5X4,5 MM
		62041	HORIZONTAL KNIFE, 6X6 MM	HORISONTALKNIV, 6X6 MM
		62043	HORIZONTAL KNIFE, 10X10 MM	HORISONTALKNIV, 10X10 MM
	50	62361	KNIFE BALK, 2X2 MM	KNIVBALK, 2X2 MM
		62362	KNIFE BALK, 2,5X2,5 MM	KNIVBALK, 2,5X2,5 MM
		62363	KNIFE BALK, 2,5X6 MM	KNIVBALK, 2,5X6 MM
	60	62364	KNIFE BALK, 4,5X4,5 MM	KNIVBALK, 4,5X4,5 MM
		62365	KNIFE BALK, 6X6 MM	KNIVBALK, 6X6 MM
		62367	KNIFE BALK, 10X10 MM	KNIVBALK, 10x10 mm
<b>Grater/Shredder</b>	70	3348 1.5	PLATE FOR 1,5 MM, GRATER	PLÅT TILL 1,5 MM
		3348 2	PLATE FOR 2 MM, GRATER	PLÅT TILL 2 MM
		3348 3	PLATE FOR 3 MM, GRATER	PLÅT TILL 3 MM
		3348 4.5	PLATE FOR 4.5 MM GRATER	PLÅT TILL 4,5 MM
		3348 6	RFG PLATE, 6 MM	PLÅT TILL 6 MM
		3348 8	PLATE FOR 8 MM, GRATER	PLÅT TILL 8 MM
		3348 10	PLATE FOR 10 MM, GRATER	PLÅT TILL 10 MM
<b>Fine Grater</b>	80	62111	PLATE, FINE GRATER	PLÅT, FINRIVARE
	85	62562	PLATE, GRATER EXTRA FINE	PLÅT, RIVARE EXTRA FIN
<b>Potato Chips Grid</b>	90	35734	COMPL. KIT KNIVES POTATO CHIPS	UTBYTESSATS KOMPL POMMES GALLE

\* Standard Slicer Knife

**Drawing: Drawings - Cutting Tools 215 m m, RG-300/350/400 and for RG-6/61/1**

